



KYMCO

PRESS INFORMATION

X-Town 300i / 125i



Beyond Touring A New Standard in Sport Touring Scooters

Since the beginning, KYMCO has always thought about our customers and what we can do to satisfy their needs. 2016 is fast approaching, and that means that consumers are looking for new things for the new year. Therefore, our customers are expecting us to have new, quality products for them to enjoy. KYMCO knows that its scooters need to have a quality, sporty design to stand out from other scooters. Besides a stylish appearance, our customers are looking for comfort, convenience and safety on long distance journeys. KYMCO knows what our customers need, so they decided to strengthen the exterior design and the long-haul riding experience. This revolutionary concept has taken the X-Town to a whole new level.



(more)



KYMCO

PRESS INFORMATION

X-Town 300i / 125i



X-Town

KYMCO is honored to announce our new sports touring X-Town

The X-Town has a whole new sporty appearance and provides extra comfort for a superior riding experience. In addition to an improved exterior design, KYMCO added a unique "X" shaped taillight. The new X-Town also fulfills the long-haul rider's major need: comfort. In order to achieve a maximum comfort level, the riding position has been redesigned. KYMCO has also improved the storage space which can fit up to two full-face helmets. Power, comfort and enjoyment made the X-Town.

(more)



Features

**Design Concept: Quality of life. Long-haul comfort.
Economic value for a sport touring scooter.**

(1) Stylish Touring –

The exterior is designed to be sporty, but at the same time it still has the comfort of a touring scooter. The LED running lights and the "X" shaped taillight provide great visibility during night riding. A great seat height with a spacious foot rest area provide extra comfort.

(2) Elegant –

A curved exterior body frame gives the impression of elegance. The interior uses different combinations of textures to increase its elegant look. Useful and convenient accessories have also been installed.

(3) Chrome design on control surfaces

(4) Quality Leather Seats –

The high frequency embossing process makes the leather seats more stylish.



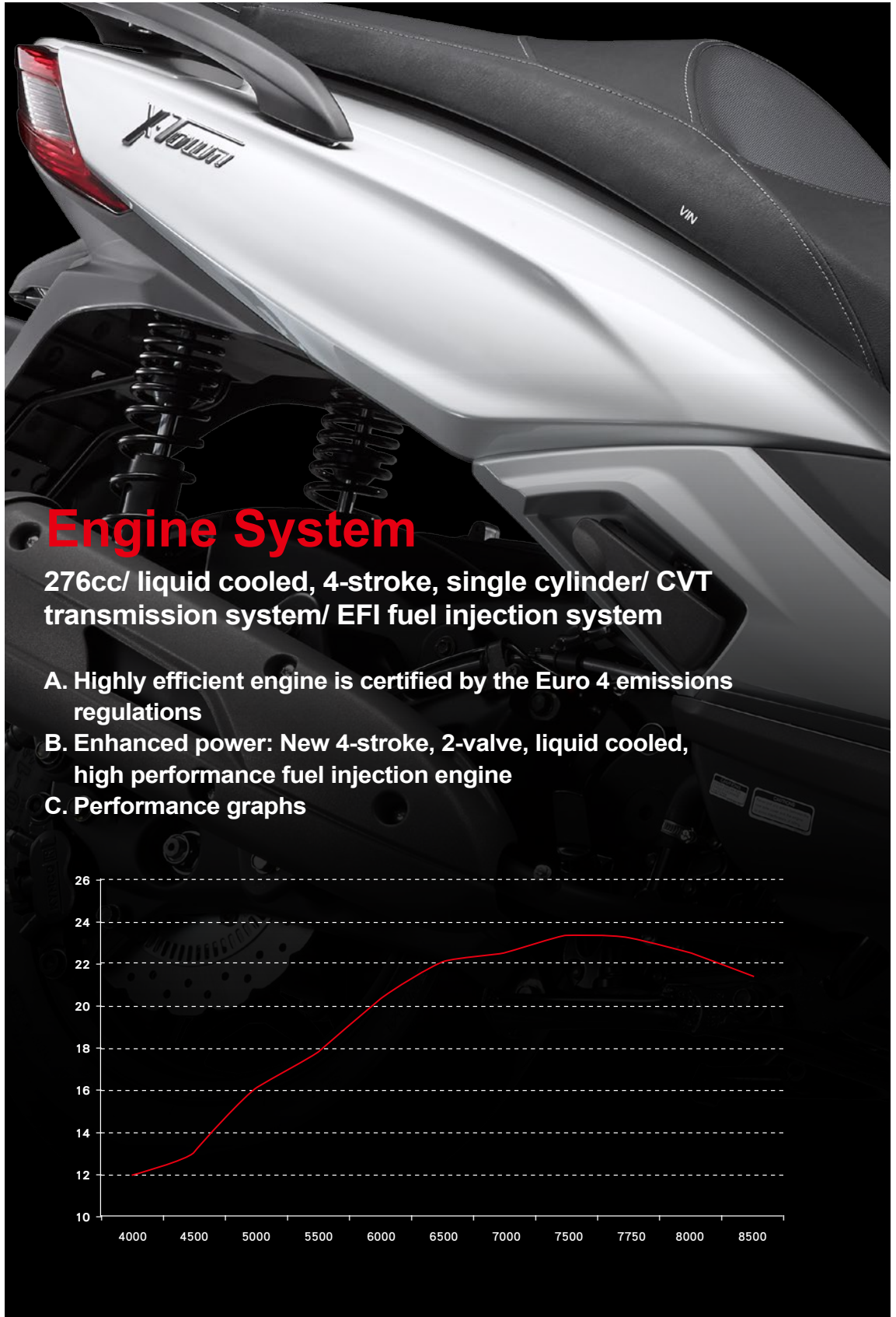

Engine System

276cc/ liquid cooled, 4-stroke, single cylinder/ CVT transmission system/ EFI fuel injection system

- A. Highly efficient engine is certified by the Euro 4 emissions regulations
- B. Enhanced power: New 4-stroke, 2-valve, liquid cooled, high performance fuel injection engine
- C. Performance graphs

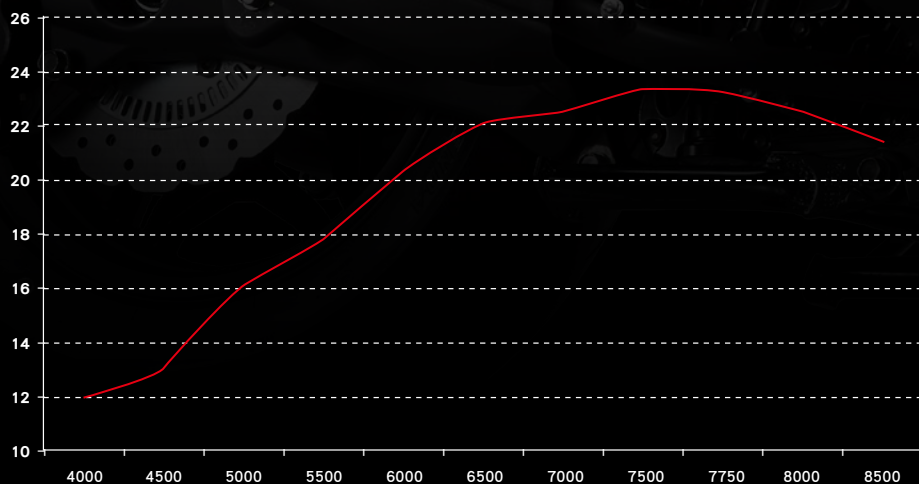

(more)



Combustion System

- Renovated compression mechanism that helps decrease the compression pressure during engine start.
- Decreases the pressure during engine start and improves sudden engine start up.
- Roller type rocker arm that reduces friction loss.

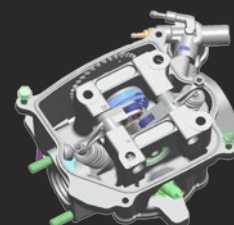

High Performance CVT System

- New design and material on the CVT system efficiency. That enhances the speed conversion efficiency.
- The wheelbase configuration design is shortened and the CVT space is used effectively.

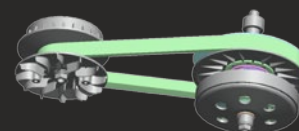

Cooling and Lubrication System

- Rectangular tank design with aluminum material that enhances engine cooling and engine life.
- Wrap-around cylinder head design enhances the cooling efficiency and engine life.

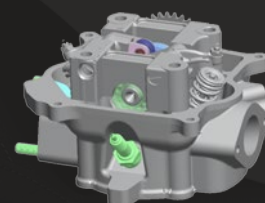

Quieter Engine Design

- Improved the rigidity of the camshaft holder and reduced valve clearance to lower engine noise.
- KYMCO uses simulation software to correct and redesign the camshaft, optimizing stability and performance levels.
- The gearbox uses helical gears that increase the gear contact ratio and reduces gear engagement noises.

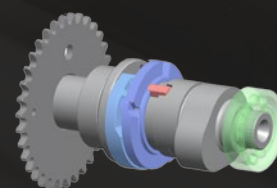



Chassis System

Highly rigid steel frame

Feature: During operation the chassis maintains high strength and rigidity that delivers stability in any road condition.

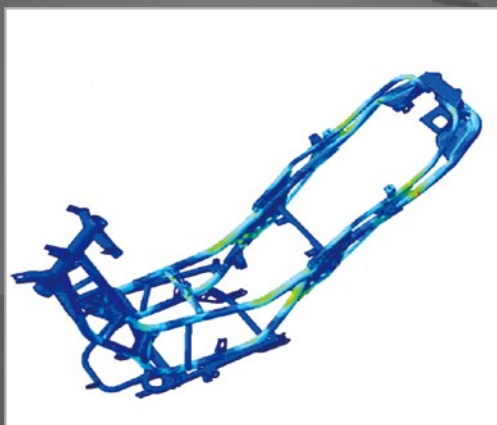

Lean Angle

Feature: Enhanced lean angle to 37° for increased cornering performance.



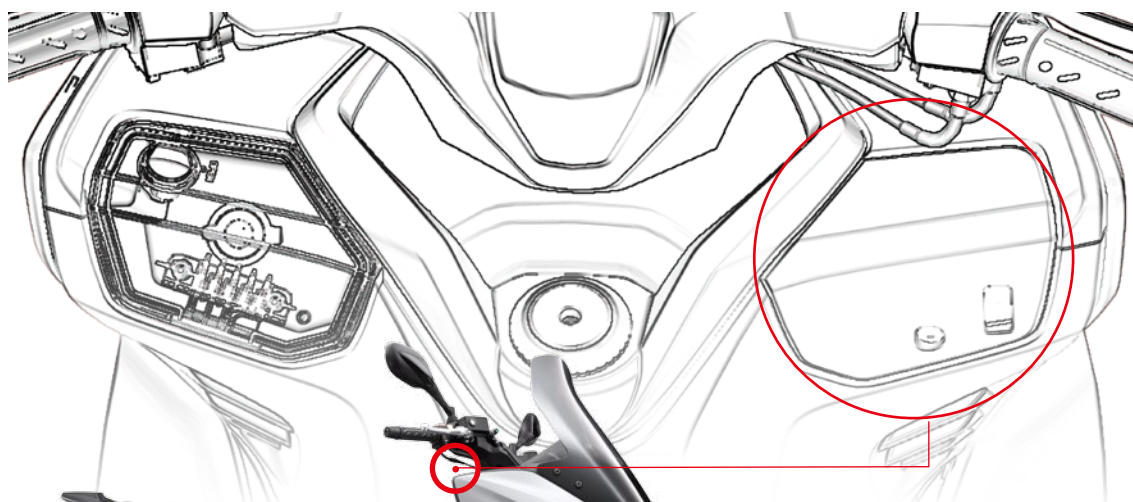

Convenient glove box with charging port

- There are two glove boxes underneath the handle bars.
- The left glove box has a built-in USB charging port for electronic devices.



Spacious under-seat storage

Can hold up to two full-face helmets

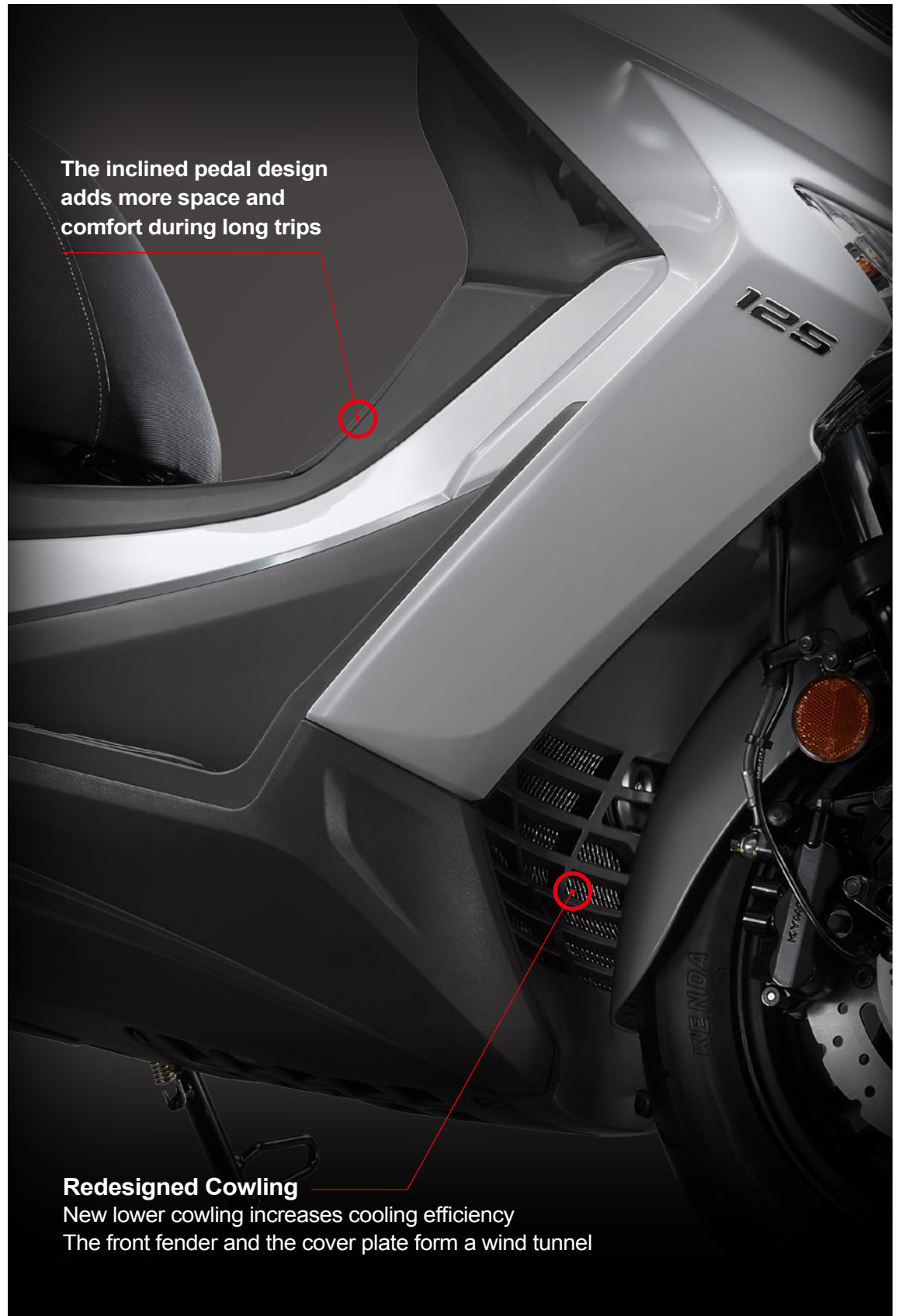

(more)



Electrical System

Information at a glance

Instrument

- Warning lights
- R/L turn indicators
- High beam
- Fuel indicator
- Oil service
- Engine check
- Low battery voltage
- Oil pressure indicator
- ABS indicator



(more)

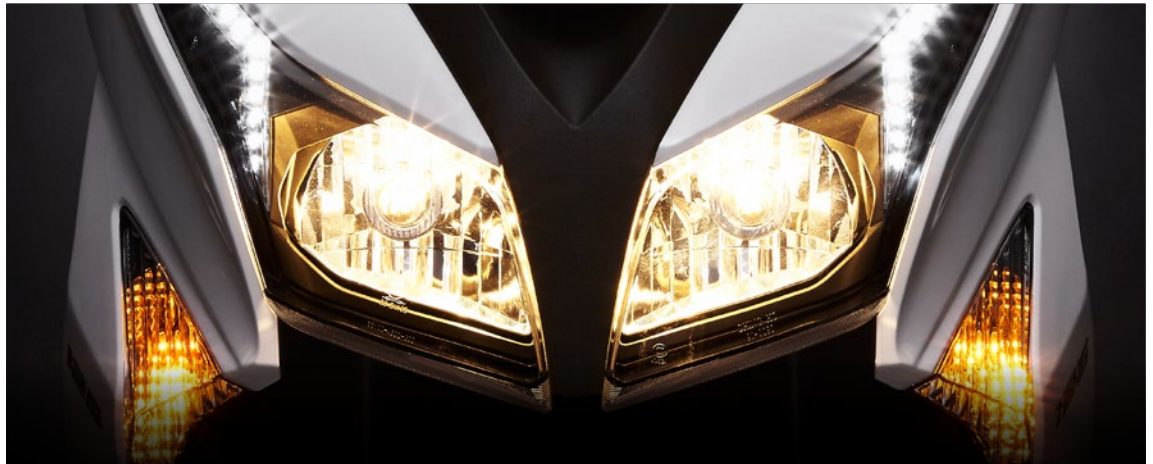

Dual Headlight

The stylish headlight design uses H7 high output light bulbs. This headlight provides outstanding lighting during night riding. The ridgeline LED running lights strengthen the sporty style of the X-Town. These features are a great choice for those who want to be unique on the street.



X-Town Featured Taillight

The LED taillight features the special "X" symbol that represents the new X-Town. The dazzling red "X", in combination with the LED signal lights, increases the visibility and safety during night riding. This work of art gives our customers the style they desire.

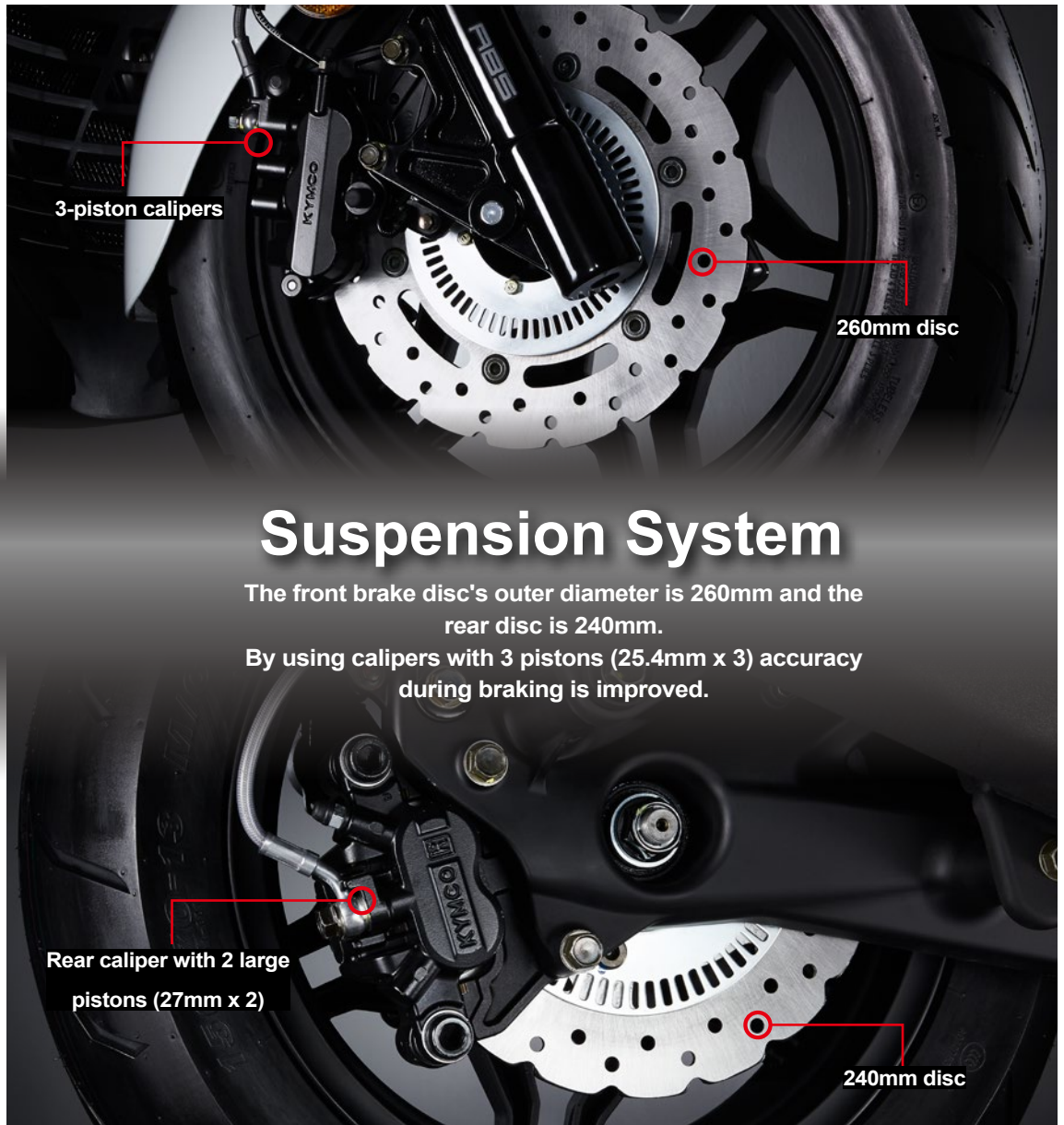

- Adjustable ergonomic brake levers design (4 segment) 1~4 = small to large
- Highly sensitive Bosch sensor provides accurate information on the dashboard

X-Town Equipped with Bosch 9.1M anti-lock braking system

9.1M ABS is equipped with the newest Sirius chip that responds faster and more reliably than the 9.0 edition. RAM is upgraded from 10kB to 16kB and the frequency from 32MHz to 40MHz.

- ※ X-Town standard ABS
- ※ 9.1M ABS system, weighs 0.7kg, currently the lightest anti-lock braking system on the market.
- ※ New X-Town Bosch ABS is reliable and acts fast during emergency braking.
- ※ Bosch ABS works with the front and rear brake disc to shorten the braking distance and provide stability.
- ※ Improved handling: the Bosch ABS works with the front/rear fork and highly rigid chassis to provide a pleasant riding experience.

(more)



Rear suspension

5 segment adjustable double swing

Front Suspension

Extendable telescopic front fork(110mm), which is 37mm in diameter, decreases vibration and improves handling.

(more)



Sports Bike Style Aluminum Rim Design

Lightweight rims are shaped to add to the overall sporty appearance



The Wheels and Tires

Front 120/80-14 with MT 3.0x14 lightweight aluminum rim

Rear 150/70-13 with MT 4.0x13 lightweight aluminum rim

(more)



PRESS INFORMATION

X-Town 300i / 125i

Specification

Model	X-Town 300i ABS	X-Town 125i ABS / CBS
Emission Regulation	Euro 4 Regulation Certified	Euro 4 Regulation Certified
Engine		
Engine Type	OHC, Liquid cooled, 2V	OHC, Liquid cooled, 4V
Fuel System	Fuel injection	Fuel injection
Displacement	276	124.8
Horsepower	18kW / 7250rpm	9.5kW / 8750rpm
Torque	25Nm / 6250rpm	11.3Nm / 6750rpm
Gearbox	CVT	CVT
Ignition	Electric	Electric
Frame		
Dry weight	181 kg	175.5 kg
WEIGHT AMOUNT	200 KG	183 KG
Dimension (L*W*H)	2250 x 800 x 1385 mm	2250 x 800 x 1385 mm
Seat Height	800 mm	800 mm
Wheelbase	1545 mm	1545 mm
FUEL TANK	12.5L	12.5L
Suspension		
Front Wheel/Tire	120/80-14	120/80-14
Rear Wheel/Tire	150/70-13	150/70-13
Rims	Aluminum Alloy	Aluminum Alloy
Front Suspension	Telescope	Telescope
Rear Suspension	Double Swing	Double Swing
Front Braking System	Disc 260mm	Disc 260mm
Rear Braking System	Disc 240mm	Disc 240mm
ABS	ABS	ABS / CBS (Option)

Photos & specification may differ from model available in your market.

(more)



KYMCO

ABOUT KYMCO

KYMCO is one of the global leading powersports brands. KYMCO's mission is to create personal vehicles that win the hearts of consumers all over the world. KYMCO always go above and beyond to bring to customers the most thoughtful riding experience for everyday life. KYMCO's current product range includes scooters, motorcycles, mobility scooters, ATVs and utility vehicles.

You can learn more about KYMCO at www.kymco.com

Company Name

*KYMCO Group
KWANG YANG MOTOR CO., LTD.*

Head Office

*80794 No.35, Wansing St., Sanmin District, Kaohsiung City, TAIWAN
Tel : +886-7-382-2526 (main)
E-mail : service@mail.kymco.com*

Established

June 1964

Chairman

Allen Ko